

TYPICAL WIRING DIAGRAM

NOTES:

1. ALL UNITS ARE DESIGNED IN ACCORDANCE WITH INDUSTRY STANDARDS.
2. TRANSFORMERS ARE DRY-TYPE, CLASS AA, VENTILATED, OPEN-STYLE ASSEMBLY FOR INDOOR/CONTROL PANEL USE.
3. TRANSFORMER ARE BASE MOUNTED.
4. TRANSFORMERS ARE CONSTRUCTED BASED UPON A 40°C AMBIENT ENVIRONMENT.
5. MAINTAIN 1" CLEARANCE FROM ALL LIVE PARTS.

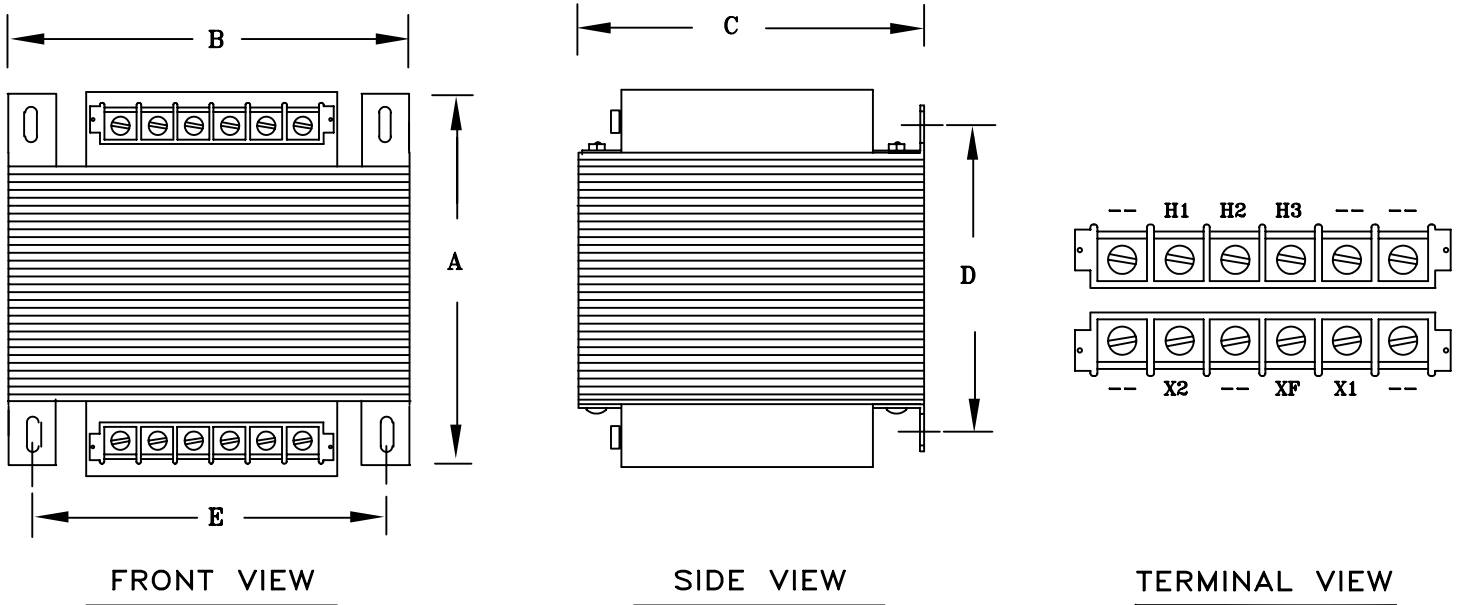

APPROXIMATE DIMENSIONS (INCHES)

| VA | A | B | C | D | E | PRIMARY FUSE BLOCK * | PRIMARY FUSE BLOCK COVER | PRIMARY/SECONDARY TERMINAL COVER | STEEL | lbs. |
|-----|------|------|------|------|------|----------------------|--------------------------|----------------------------------|--------|------|
| 500 | 6.11 | 5.25 | 4.63 | 3.88 | 4.38 | TPTC-1006-1 | TPTC-1006-2 | TPTC-1012-A | EI-175 | 16 |

* IF YOU PURCHASE THE PRIMARY FUSE BLOCK, IT WILL ADD 1.50" TO THE "C" DIMENSION
 ** IF YOU UTILIZE THE SECONDARY FUSE CLIPS, THEY WILL ADD 0.50" TO THE "C" DIMENSION

DRAWINGS
 APPROVAL
 RECORD
 OTHER

| | | | | | |
|------------------------|--|-----------|-----------|-------|--|
| PRIMARY VOLTAGE | 208-277 | CUST. | XXXXXXXX | | |
| SECONDARY VOLTAGE | 120 | JOB | | | |
| TEMPERATURE RISE IN °C | 80 | CATALOG | | | |
| WINDINGS & TERMINALS | <input type="checkbox"/> ALUMINUM <input checked="" type="checkbox"/> COPPER | NOTE | XXXXXXXX | | |
| FREQUENCY HERTZ | 50/60 | BY | ENG. LOG. | TITLE | 1-PHASE, 600 VOLT CLASS CONTROL DRY TYPE TRANSFORMER |
| PRIMARY TAPS | NONE | DATE | | | |
| POWERTRAN | REV | MFG. LOG. | DWG. NO. | | B500MQ15XKF |
| | DATE: | DWG. FILE | | | |